

With an ultra-thin 9mm profile, double-sided frosted diffuser, and advanced ADC12 aluminum cooling frame, this dimmable LED light offers even illumination, energy efficiency (PF > 0.9), and IP40 protection for wet locations.

**Dimensions for 4-inch: Cut-out size: 4.25"**

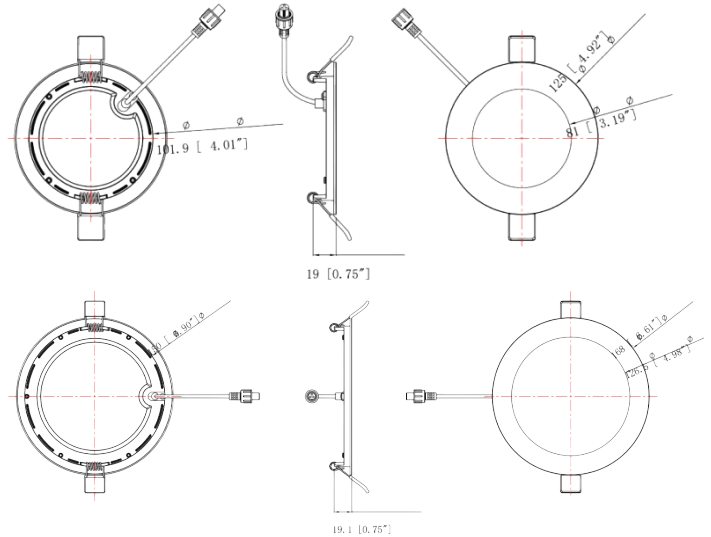
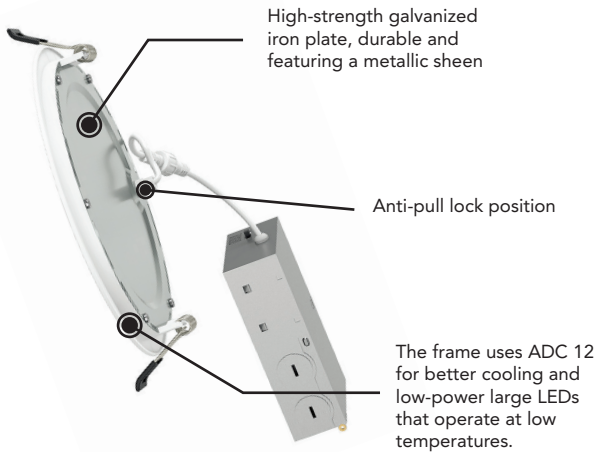

**Dimensions for 6-inch: Cut-out size: 6.375"**

**Key Features**

- Ultra-thin 0.35-inch profile.
- 5CCT options: 2700K-5000K.
- High CRI > 90.
- Even light distribution, frosted diffuser.
- Triac dimmable, 5%-100%.
- ADC12 aluminum cooling frame.
- High power factor (>0.9).
- IP40 listed; suitable for wet location.
- Connector with strain relief design.
- Great spring elasticity, 6N-8N force.
- 50,000 hour life.
- 5 year limited warranty.

**Specifications**

Sizes	4" and 6"
Input Voltage	120V AC
Wattage	9W and 12W
Lumens	738Lm, >984Lm
Beam Angle	110 Degree
CCT	5CCT (2700 - 5000K)
CRI	>90
Lifespan	50,000 Hours
Limited Warranty	5years
Approvals	cETLus

**Ordering Code(s)**

	1 Pack	6 Pack	12 Pack	24 Pack
<b>4"</b>	SDL-5CCT-4-WH-1P	SDL-5CCT-4-WH-6P	SDL-5CCT-4-WH-12P	SDL-5CCT-4-WH-24P
<b>6"</b>	SDL-5CCT-6-WH-1P	SDL-5CCT-6-WH-6P	SDL-5CCT-6-WH-12P	SDL-5CCT-6-WH-24P

Project			Type		
Date			Contact		
Notes					